

Owner's Manual

Outboard Motor Series

● **18F**

● **20F**



YOUR OUTBOARD MOTOR

OWNER REGISTRATION AND IDENTIFICATION

Upon purchasing this product, be sure that the warranty card is correctly and completely filled out and mailed to the addressee noted there on. This warranty card identifies you as the legal owner of the product and serves as your warranty registration. To the extent permitted by applicable law, your outboard motor will not be covered by the applicable limited warranty, if this procedure is not followed.

PRE-DELIVERY CHECK

Be sure that the product has been checked by an authorized dealer before you take delivery.

Limited Warranty

Please refer to the outboard motor warranty provided to you with this product, the terms and conditions of which, as amended from time to time, are incorporated by reference into the manual.

Serial Number

In the space below, please record the outboard motor's serial number (indicated both on the bottom cowl and on the cylinder block). The serial number will be needed in ordering spare parts and the event of theft or to quickly identifying the outboard motor type.

Serial Number : _____

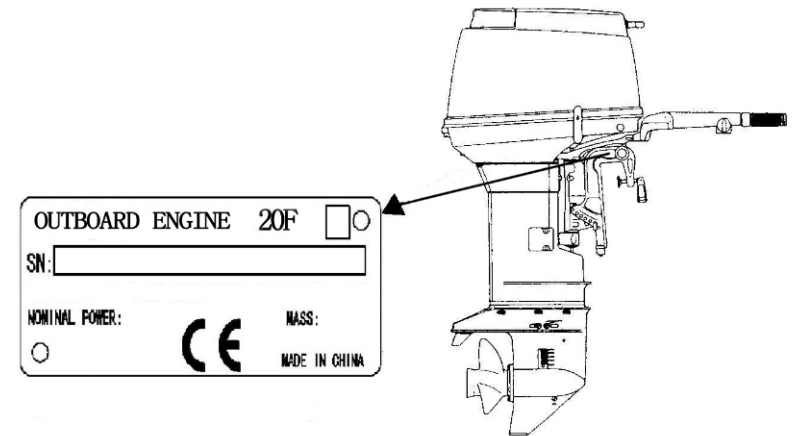

To You, Our Customer

Thank you for selecting this outboard motor. You are now the proud owner of an excellent outboard motor that will service you for many years to come.

This manual should be read in its entirety and the inspection and maintenance procedures described later in this manual should be followed carefully. Should a problem arise with the outboard motor, please follow the troubleshooting procedures listed at the end of this manual. If the problem persists, contact an authorized service shop or dealer.

We hope you will enjoy your outboard motor and wish you good luck in your boating adventures.

CONTENTS

GENERAL SAFETY INFORMATION	1
1. SPECIFICATIONS	4
2. NAMES OF PARTS	5
3. INSTALLATION	6
1. Mounting the outboard motor on boat	6
2. Propeller Selection	8
4. PRE-OPERATING PREPARATIONS	9
1. Recommended gasoline types	9
2. Recommended engine oil	11
3. Break-in	13
5. ENGINE OPERATION	14
1. Starting	14
2. Warming up the engine	16
3. Forward and reverse	16
4. Stopping	19
5. Trim angle	20
6. Tilt up, tilt down and shallow water operation	21
6. REMOVING AND CARRYING THE OUTBOARD MOTOR	24
1. Removing the outboard motor	24
2. Carrying the outboard motor	24
3. Storing the outboard motor	24
7. TRAILERING	25
8. ADJUSTMENT	26
1. Trim tab adjustment	26
2. Steering load adjustment	27
3. Throttle grip turning load adjustment	28
9. INSPECTION AND MAINTENANCE	29
1. Daily inspection	30
2. Periodic inspection	34
3. Off-season storage	37
4. Pre-season check	38
5. Motor submerged in water	38
6. Cold weather precautions	39
7. Checking after striking underwater object	39
10. TROUBLESHOOTING	40

GENERAL SAFETY INFORMATION

NOTICE : DANGER/WARNING/CAUTION/Note

Before installing, operating or otherwise handling your outboard motor, be sure to thoroughly read and understand this Owner's Manual and carefully follow all of the instructions. Of particular importance is information preceded by the words "DANGER," "WARNING," "CAUTION," and "Note." Always pay special attention to such information to ensure safe operation of the outboard motor at all times.

DANGER

Failure to observe will result in severe personal injury or death, and possibly property damage.

WARNING

Failure to observe could result in severe personal injury or death, or property damage.

CAUTION

Failure to observe could result in personal injury or property damage.

Note

This instruction provides special information to facilitate the use or maintenance of the outboard motor or to clarify important points.

EMERGENCY STOP SWITCH

The Emergency Stop Switch will stall the outboard motor when the stop switch tether is pulled off. This stop switch tether can be attached to the operator of the outboard motor to minimize or prevent injuries from the propeller in case the operator falls overboard. We highly recommend use of the Emergency Stop Switch tether.

WARNING

Accidental activation of the Emergency Stop Switch (such as the tether being pulled out in heavy seas) could cause passengers to lose their balance and even fall overboard, or it could result in loss of power in heavy seas, strong currents, or high winds. Loss of control while mooring is another potential hazard.

To minimize accidental activation of the Emergency Stop Switch, the 500 mm (20 inch.) stop switch tether is coiled and can extended to a full 1300 mm (51 inch.).

SAFE OPERATION OF BOAT

As the operator/driver of the boat, you are responsible for the safety of those aboard and those in other boat around yours, and for following local boating regulations. You should be thoroughly knowledgeable on how to correctly operate the boat, outboard motor, and accessories. To learn about the correct operation and maintenance of the outboard motor, please read through this manual carefully.

It is very difficult for a person standing or floating in the water to take evasive action should he or she see a power boat heading in his /her direction, even at a slow speed. Therefore, when your boat is in the immediate vicinity of people in the water, the outboard motor should be shifted to neutral and shut off.

WARNING

SERIOUS INJURY IS LIKELY IF A PERSON IN THE WATER MAKES CONTACT WITH A MOVING BOAT, GEAR HOUSING, PROPELLER, OR ANY SOLID DEVICE RIGIDLY ATTACHED TO A BOAT OR GEAR HOUSING.

SERVICING, REPLACEMENT PARTS & LUBRICANTS

We recommend that only an authorized service shop perform service or maintenance on this outboard motor. Be sure to use genuine parts, genuine lubricants, or recommended lubricants.

MAINTENANCE

As the owner of this outboard motor, you should be acquainted with correct maintenance procedures. It is the operator's responsibility to perform all safety checks and to ensure that all lubrication and maintenance instructions are complied with for safe operation. Please comply with all instructions concerning lubrication and maintenance. You should take the engine to an authorized dealer or service shop for periodic inspection at the prescribed intervals.

Correct periodic maintenance and proper care of this outboard motor will reduce the chance of problems and limit overall operating expenses.

MOUNTING

Outboard motor mounting must be performed by trained service person(s) using lift or hoist with sufficient capacity.

SPECIFICATIONS

18F/20F

Item	MODEL	18F	20F
Overall Length	mm (in)	876 (34.2)	
Overall Width	mm (in)	345 (13.6)	
Overall Height	S mm (in)	1067 (42.0)	
Weight	S kg (lb)	41 (90)	
Output	kW (Hp)	13.2(17.9)	14.5(19.7)
Max. Operating Range	rpm	5200–5800	
Number of Cylinders		2	
Piston Displacement	mL (Cu in)	326(19.9)	
Bore x Stroke	mm (in)	62 x 54 (2.44x2.12)	
Exhaust System		Through hub exhaust	
Engine Lubrication		Engine Oil Mixed Gasoline	
Cooling System		Forced water cooling	
Starting System		Manual	
Ignition System		Flywheel Magneto C.D. Ignition	
Spark Plugs		BPR7HS-10	
Trim Position		6	
Engine Oil Mixing Ratio		Unleaded Gasoline 50 : Genuine 2-stroke Engine Oil 1	
Gear Oil		SAE #80 to #90, approx. 370mL	
Fuel Tank Capacity	L (US gal)	24 (6.6)	
Gear Reduction Ratio		27:13	
Fuel		Unleaded regular gasoline : Pump posted 87 Octane (research octane rating of 91)	

NAMES OF PARTS

18F/20F

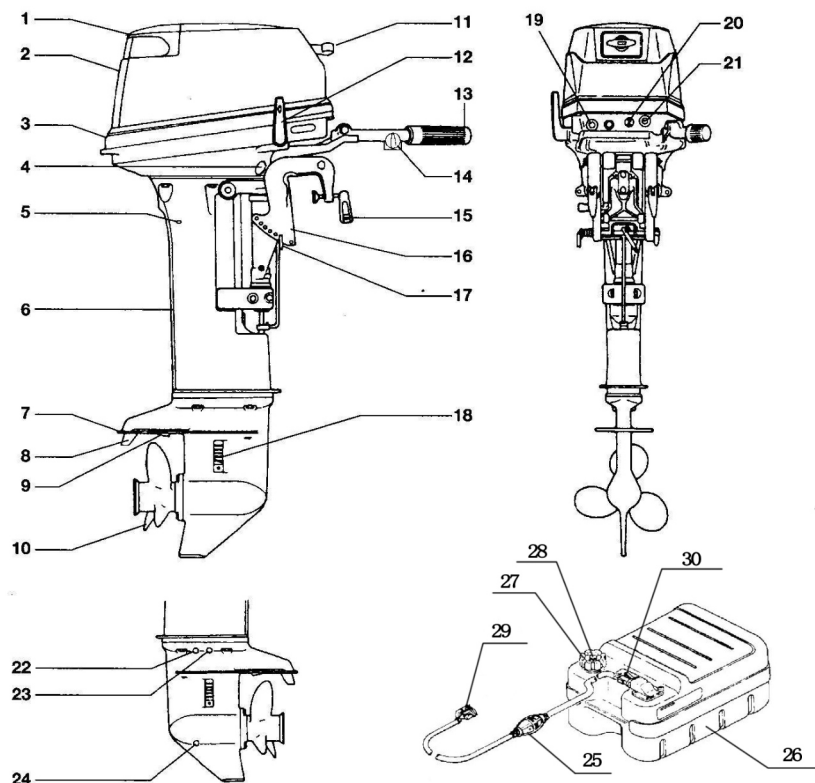

- | | | |
|----------------------------|-------------------|----------------------------|
| 1 Tilt Handle | 11 Starter Handle | 21 Fuel Connector (Male) |
| 2 Top Cowl | 12 Shift Lever | 22 Oil Plug (Upper) |
| 3 Bottom Cowl | 13 Throttle Grip | 23 Water Plug |
| 4 Reverse Lock Lever | 14 Adjust Nut | 24 Oil Plug (Lower) |
| 5 Cooling Water Check Port | 15 Clamp Screw | 25 Primer Bulb |
| 6 Drive Shaft Housing | 16 Clamp Bracket | 26 Fuel Tank |
| 7 Anti Ventilation Plate | 17 Thrust Rod | 27 Fuel Connector (Female) |
| 8 Anode / Trim Tab | 18 Water Inlet | 28 Fuel Tank Cap |
| 9 Sub Water Inlet | 19 Stop Switch | 29 Air Vent Screw |
| 10 Propeller | 20 Choke Knob | 30 Fuel Pick Up Elbow |

INSTALLATION

1. Mounting the outboard motor on boat

⚠ WARNING

Most boats are rated and certified in terms of their maximum allowable horsepower, as shown on the boat's certification plate. Do not equip your boat with an outboard motor that exceeds this limit. If in doubt, contact your dealer. Do not operate the outboard motor until it has been securely mounted on the boat in accordance with the instructions below.

2 To attach the outboard motor to the boat, tighten the clamp screws by turning their handles.

Also, use the bolts to secure the outboard motor brackets on transom board.

Secure the outboard motor with a rope to prevent loss overboard.

Note

A rope is not included in the standard accessories.

Installation

■ Single-engine Installation

Set engine at center of boat.

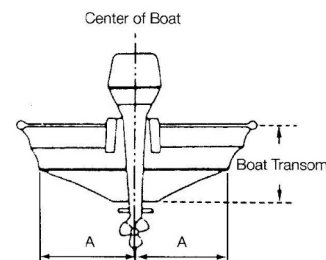

Transom matching

- 1 Be sure that the anti ventilation plate of the outboard motor is 30-50mm (1.2-2 in) below the bottom of hull. If the above condition cannot be met due to the shape of the bottom of your boat, please consult your authorized dealer.

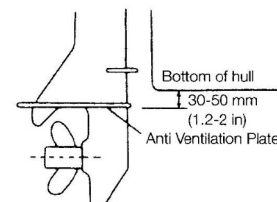

INSTALLATION

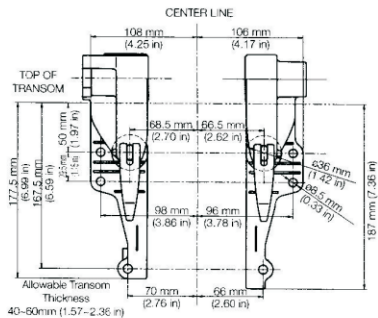
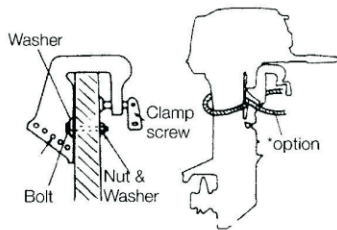

CAUTION

- Before beginning the running test, check that the boat with maximum capacity loading floats on the water in a proper attitude. Check the position of water surface on the driveshaft housing. If the water surface is near the bottom cowling, in high waves, water may enter the engine cylinders.
- Incorrect outboard motor mounting height or existence of underwater object(s), such as hull bottom design, bottom surface conditions or underwater accessories, can cause water spray possibly reaching the engine through an opening of the bottom cowling during cruising. Exposing engine to such conditions for extended periods can lead to severe engine damage.

CAUTION

Mounting bolts should be installed with the bolt head at inside surface of the transom. Mounting bolts installed with the threaded end at the inside surface of the transom can cause personal injury.

Notes

- 1 Apply sealing agent, such as silicone sealed between the bolts and the transom board holes before tightening the bolts.
- 2 Be sure to tighten the mounting bolt nuts to the specified torque.
(30 Nm (13ft·lb) 3.0kgf)

WARNING

- Mounting the outboard motor without following this manual can lead to unsafe conditions such as poor maneuverability, lack of control or fire.
- Loose clamp screws and/or mounting bolts can lead to the release or displacement of the outboard motor, possibly resulting in lost of control and/or serious personal injury. Be sure that fasteners are tightened to the specified torque (30Nm (13ft·lb) 3.0kgf). Check the fasteners for tightness from time to time.
- Be sure to use outboard mounting fasteners included in the outboard motor package or their equivalents in terms of size, material, quality and strength. Tighten fasteners to the specified torque (30Nm (13ft·lb) 3.0kgf). Test cruise to check if fasteners are tightened securely.
- Outboard motor mounting must be performed by trained service person(s) using lift or hoist with sufficient capacity.

2. Propeller Selection

A propeller must be selected so that the engine rpm measured at wide open throttle while cruising is within the max. operating range;

PRE-OPERATING PREPARATIONS

DANGER

Consult an authorized dealer for details on handling of gasoline, if necessary.

Gasoline and its vapors are very flammable and can be explosive.

When carrying a fuel tank containing gasoline:

- Close the air vent screw of fuel tank cap, or gasoline vapor will be emitted through the air vent screw, creating a fire hazard.
- Do not smoke.

When or before refueling :

- Stop the engine, and do not start the engine during refueling.
- Do not smoke.
- Be careful not to overfill fuel tank. Wipe up any spilled gasoline immediately.

When or before cleaning the gasoline tank :

- Dismount fuel tank from the boat.
- Place the fuel tank away from every source of ignition, such as sparks or open flames.
- Do the work outdoors or in well ventilated area.
- Wipe up any spilled gasoline immediately.

After cleaning gasoline tank :

- Wipe up any spilled gasoline immediately.
- If the fuel tank is disassembled for cleaning, reassemble carefully. Imperfect assembly may cause a fuel leak, possibly leading to fire or explosion.
- Dispose of aged or contaminated gasoline in accordance with local regulations.

1. Recommended gasoline types

CAUTION

Use of low-quality gasoline results in a short engine life as well as starting difficulties and other engine problems. We recommend use for Fuel stabilizer.

Use of unleaded gasoline

Use a major brand of automotive unleaded gasoline with a minimum posted octane rating of 91RON. Automotive gasoline that contain fuel injector cleaner are preferred for added internal engine cleanliness. Leaded gasoline is acceptable in areas where unleaded gasoline is not available.

PRE-OPERATING PREPARATIONS

Use of alcohol free gasoline

CAUTION

Use of gasoline containing alcohol can cause engine starting and/or operating difficulties, wear of and damages to engine parts, and deterioration of chemical parts, which may lead to shortening of your outboard motor's life.

Note

The adverse effect caused by the alcohol content is more severe with methanol than with ethanol.

Dealers recommend the use of gasoline if its ethanol content is less than 10% or methanol content is less than 5%, only in case alcohol free gasoline is not available.

The alcohol component of the gasoline absorbs moisture from the air, which may disturb regular fuel flow in the fuel system, and also accelerate rusting of engine parts.

Mixing of the moisture in the engine oil can also deteriorate the properties of the lubricant.

If the use of gasoline containing alcohol is inevitable, or presence of alcohol is suspected in the gasoline, it is strongly recommended to add a filter that has water separating capability, and check the fuel system for leaks and mechanical parts for corrosion and abnormal wear more frequently.

And, in case any of such abnormality is found, discontinue the use of such gasoline and contact our dealer immediately.

Damages resulting from the use of gasolines that contain alcohol are not covered under the limited warranty.

Fuel tank capacity : 25 liters (6.6 U.S. gal)

Fuel Tank : When using a fixed fuel tank in place of genuine fuel tank, it is recommended to select a one with a structure facilitating interior cleaning.

WARNING

Do not fill the fuel tank over capacity. The rise of gasoline temperature may cause gasoline to expand which, if overfilled, may leak through air vent screw when it is open. Leaking gasoline is a dangerous fire hazard.

PRE-OPERATING PREPARATIONS

2. Recommended engine oil

Use a genuine engine oil or recommended one (TCW3). Refer to your Distributor. Will not recommend use of other two stroke engine oil.

CAUTION

Do not mix different brands of oil. Mixing different brands of oil, or different types of oil even if the brand is the same, may cause gelling, resulting in possible filter screen blockage. This could result in serious engine damage because of impaired lubrication performance.

Note

Use of engine oils that do not meet these requirements will result in reduced engine life, and other engine problems.

Add engine oil into fuel oil tank. The mixing ratio with gasoline is 1 : 50 (one part oil and 50 parts gasoline). Mix well by hand. The mixing ratio during break-in running is 1 : 25.

Mixing Ratio

	Engine Oil : Gasoline
During break-in	1 : 25
After break-in	1 : 50

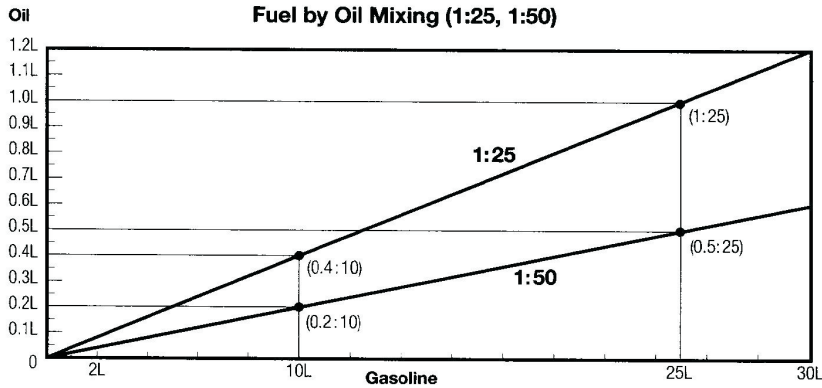

Engine oil – gasoline mixing procedure

For quantities of engine oil and gasoline to be pre-mixed, refer to table in previous page.

CAUTION

- Do not use other than two stroke engine oil with specified grade, or the engine may be damaged.
- Do not use fuel prepared in other than specified mixing ratio.
 - Lack of engine oil can cause severe engine trouble such as piston seizure.
 - Excess of engine oil can shorten spark plug life, and/or cause increase of noxious exhaust.

■ When portable fuel tank is used for operation of outboard motor(s):

- 1 Pour engine oil into fuel tank, and then, gasoline.
- 2 Put cap on the tank, and close tightly.
- 3 Close air vent plug tightly.

WARNING

Loose cap or air vent plug can cause leak of fuel during shaking the tank.

- 4 Shake the tank to mix engine oil and gasoline well and even.

■ When fuel tank built in the boat is used for operation of outboard motor(s):

- 1 Prepare separate fuel container for pre-mixing.

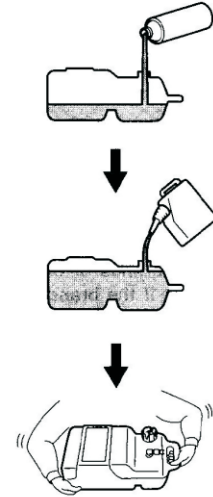

- 2 Pour engine oil into fuel container, and then, gasoline.
- 3 Put cap on the container, and close tightly.
- 4 Shake the container to mix engine oil and gasoline well and even.
- 5 Pour the mixture into fuel tank.

Notes

- It is recommended to pre-mix by using separate fuel container. Attempting to pre-mix in the fuel tank built-in the boat can make the mixture uneven.
- If built-in fuel tank is used for mixing, pour engine oil into the tank little by little while putting gasoline into the tank.

PRE-OPERATING PREPARATIONS

3. Break-in

Your new outboard motor and lower unit require break-in for the moving components according to the conditions described in the following time table.

⚠ CAUTION

Operating the outboard motor without break-in can shorten service life of the product.

If any abnormality is experienced during the break-in:

- **Discontinue the operation immediately.**
- **Have the dealer check the product and take proper action(s) if necessary.**

	1-10min	10min-2hrs	2-3hrs	3-10hrs	After 10hrs
Throttle Position	Idle	Less than 1/2 throttle	Less than 3/4 throttle	3/4 throttle	Full throttle available
Speed		Approx. 3,000 rpm max	Full throttle run allowed for 1 min every 10 min	Approx. 4,000 rpm. Full throttle run allowed for 2 min every 10 min	

Note

Proper break-in allows outboard motor to deliver its full performance for longer service life.

Fuel mix ratio for break-in

Gasoline 25: Genuine Engine Oil 1

- 25:1 when using genuine engine oil or the recommended one (TCW3).

⚠ DANGER

Do not operate the outboard motor in closed area or area with no forced ventilation.

Exhaust gas emitted by this outboard motor contains carbon monoxide that will cause death if inhaled continuously. Inhaling the gas initially causes symptoms such as feeling of sickness, drowsiness and headache.

During operation of the outboard motor :

- **Keep peripheral area well ventilated.**
- **Always attempt to stay on the windward side of emission.**

ENGINE OPERATION

1. Starting

⚠ WARNING

In case engine starts in gear, do not start cruising. Stop engine immediately and consult an authorized dealer.

Note

The engine will not start unless the switch lock has been properly connected into the emergency stop switch.

⚠ WARNING

Do not operate the engine with gear case out of water.

Severe personal injury, or engine damage will result.

⚠ CAUTION

Never fill up portable fuel tanks on board to avoid fire or explosion resulting from spilled gasoline. If gasoline is ever spilled on board, wipe it up thoroughly. Fuel tanks must always be filled up on land.

Preparations

- 1 Loosen the air vent screw on the tank cap.

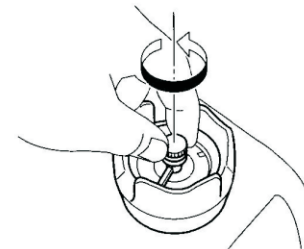

- 2 Connect the fuel connector to the engine.

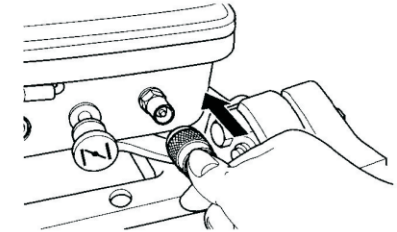

- 3 Install a lock in the stop switch.

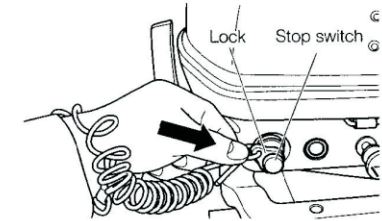

- 4 Feed fuel to the carburetor by squeezing the primer bulb until firm.

Engine side

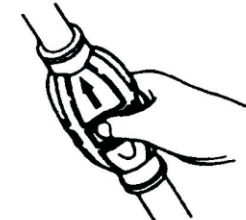

Fuel tank side

- 5 Place the shift lever in the Neutral position.

Be sure that the shift is in Neutral when starting the engine.

This model is provided with start in gear protection.

ENGINE OPERATION

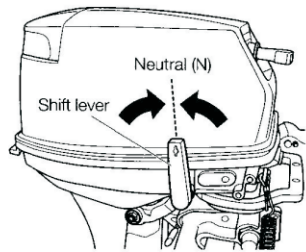

CAUTION

If the engine starts in gear, do not use it. Contact an authorized dealer.

Note

Start-in-gear protection prevents engine from starting at other than neutral shift. In-gear starting of engine will move the boat immediately, potentially leading to falling down or causing passenger(s) to be thrown overboard.

- 6 Turn the throttle grip until the mark on the grip faces the triangular mark on the steering handle.

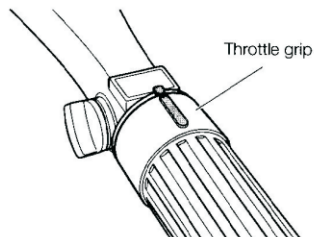

- 7 Pull out the choke knob all the way. (No choke operation is necessary when the engine is warm.)

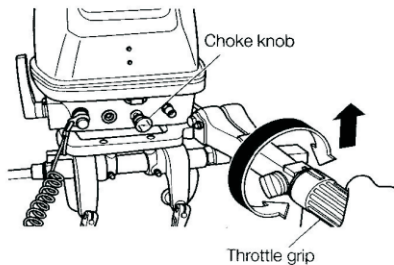

- 8 Pull the starter handle slowly until you feel resistance. Then pull it quickly.

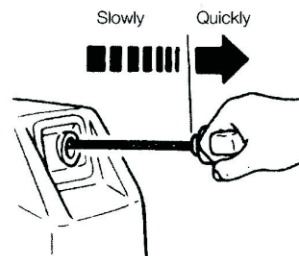

If the recoil starter fails to operate

- Remove the top cowl and the recoil starter. Wrap a rope around the starter pulley then pull quickly to start.
- Use a 10 mm socket wrench as a rope handle.

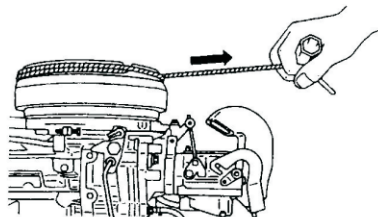

ENGINE OPERATION

WARNING

Be careful that your clothes or other items do not get caught in the rotating engine parts.

To prevent accident and injury, do not re-attach the recoil starter after the engine has been started using the emergency starter rope. Be sure to put the top cowl back on.

Immediately contact an authorized dealer when reaching shore.

WARNING

- Be sure that no bystander(s) is within 2 meters from back of starting operator.
- Do not operate the outboard motor with top cowl removed from the power unit, or contacting turning flywheel which can lead to serious personal injury.

2. Warming up the engine

Warm the engine at low engine speeds for about three minutes. This allows the lubricating oil to circulate to all parts of the engine. Operating the engine without warm up shortens the engine's life.

Be sure to check that cooling water is coming out of the cooling water check port during warm up.

CAUTION

If the engine is operated without water discharging from the check port or idle port, the engine may over heat.

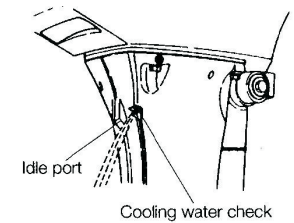

CAUTION

Be sure to stop engine immediately if cooling water check port is not discharging water, and check if cooling water intake is blocked. Operating engine could lead to overheating potentially leading to engine damage. Consult an authorized dealer if the cause cannot be found.

3. Forward and reverse

WARNING

Before shifting into forward or reverse, make sure that boat is properly moored and outboard motor can be steered fully to the right and left. Make sure that no swimmer(s) is ahead or astern of the boat.

WARNING

- Attach other end of emergency stop switch tether to the operator's clothing or arm and keep it attached during cruising.
- Do not attach the tether to a part of clothing that can be torn easily when pulled.
- Arrange the tether so that will not be caught by any object when pulled.
- Be careful not to pull the tether accidentally during cruising. Unintentional stop of engine can cause loss of control of outboard motor. Rapid loss of engine power can lead to falling down or causing passenger(s) to be thrown overboard.

WARNING

Be sure to connect the emergency tethered stop hook to your waist or clothing. The engine will shut down when the switch lock becomes disconnected from the engine.

ENGINE OPERATION

Notes

- Do not increase engine speed unnecessarily in reverse.
- Confirm that the reverse lock lever is at "LOCK" position before running your motor.

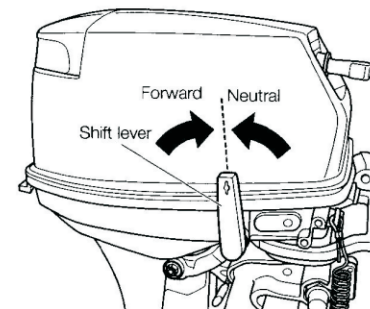
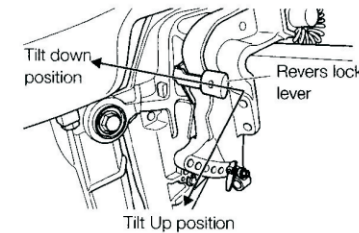

WARNING

Severe damage, and personal injury, may occur if shifting at high engine speed. Engine must be in the slow idle position before shifting is attempted.

Forward

Turn the throttle grip to reduce engine speed. When the engine reaches trolling (or idling) speed, quickly pull the shift lever to the Forward position.

Reverse

Reduce engine speed, when the engine reaches trolling (or idling) speed, quickly push the shift lever to the Reverse position.

WARNING

Before shifting, make sure that no swimmer(s) or obstacle(s) is ahead or astern of the boat.

CAUTION

Be sure to warm up engine well before starting cruise. Operating cold engine may cause damage to your motor.

CAUTION

- Before moving the Shift Lever to Reverse, make sure the Reverse Lock is engaged (in up position).

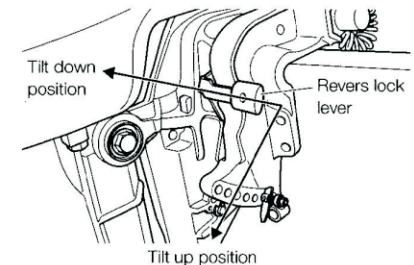

- Do not increase the engine speed unnecessarily while reversing.
- The Shift Lever cannot be turned from Neutral to Reverse unless the throttle grip has been turned fully toward "SLOW".

ENGINE OPERATION

Note

Idle speed may be higher during warming up of engine. If shifted to Forward or Reverse during warming up, it may be difficult to shift back to neutral. In such case, stop engine, shift to neutral, and restart engine to warm up.

Note

Frequent shifting to forward or reverse can accelerate wear or degradation of parts. In such case, replace gear oil earlier than the period specified.

4. Stopping

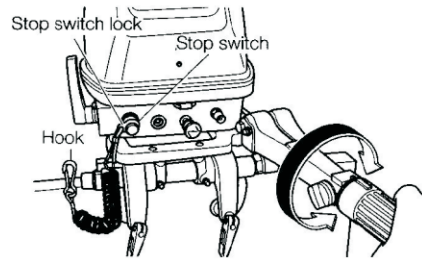

- 1 Turn the throttle grip to the slow position.
- 2 Put the shift lever in the Neutral position. Run the engine for 2-3 minutes at idling speed if it has been running at full speed.
- 3 Push the stop switch to stop the engine or release the stop switch lock.

WARNING

- Do not shift into Reverse during planing, or control will be lost leading to serious personal injury, boat may swamp, and/or hull may be damaged.
- Do not shift into Reverse during cruising, or control may be lost, falling down or causing passenger(s) to be thrown overboard. Leading to serious personal injury, and steering system and/or shifting mechanism may be damaged.

ENGINE OPERATION

5. Trim angle

The trim angle of the outboard motor can be adjusted to suit the transom angle of the hull, and load conditions. Choose an appropriate trim angle that will allow the anti ventilation plate to run parallel to the water surface during operation.

Proper trim angle

The position of the thrust rod is correct if the hull is horizontal during operation.

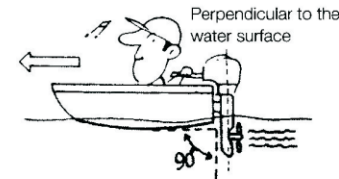

Improper trim angle (bow rise too high)

Set the thrust rod lower if the bow of the boat rises above horizontal.



Improper trim angle (bow dips into the water)

Set the thrust rod higher if the bow of the boat is below horizontal.

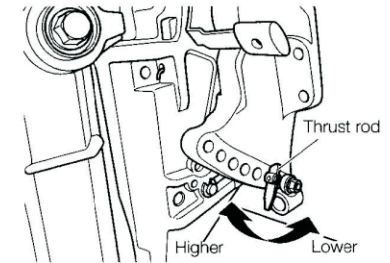

WARNING

- Do not put hand or finger in between outboard motor body and clamp bracket when adjusting trim angle to prevent injury in case the outboard motor body falls.
- Unsuitable trim position can cause loss of control of boat. When testing a trim position, run boat slow initially to see if it can be controlled safely.

WARNING

Excessive trim up or down may lead to unstable boat operation, potentially causing the steering difficulty that leads to accident during cruising.

- Do not cruise at high speed if improper trim position is suspected. Stop the boat and readjust trim angle before continuing cruise.

ENGINE OPERATION

6. Tilt up, tilt down and shallow water operation

⚠ WARNING

When tilting up or down, be careful not to place your hand between the swivel bracket and the stern bracket.

Be sure to tilt the outboard motor down slowly.

Note

Stop the engine before tilting up.

Tilt up

Push the reverse lock lever down until it stops. (This is the tilt up position.) Now, tilt the outboard motor all the way up until it is locked in place.

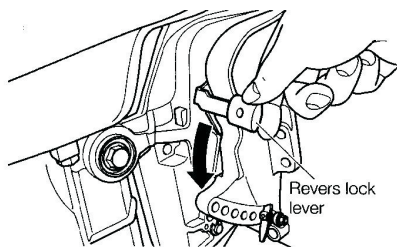

⚠ WARNING

- Do not put hand or finger in between outboard motor body and clamp bracket when adjusting trim angle to prevent injury in case the outboard motor body falls.
- When tilting up outboard motor with fuel joint for over a few minutes, be sure to disconnect fuel hose or close fuel cock,

or fuel may leak, potentially catching fire.

⚠ CAUTION

Do not tilt up outboard motor during operation, or engine may be damaged from overheating due to lack of sufficient cooling water.

Tilt down

Pull the reverse lock lever upward until it stops. (This is the tilt down position.) Now, lift up the outboard motor slightly, and then allow gravity to lower it for you.

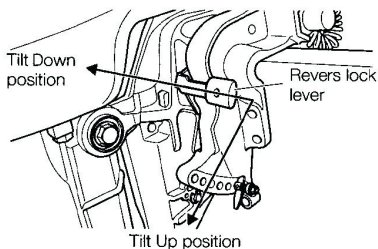

Shallow water operation

⚠ WARNING

During shallow water operation, be careful not to place your hand between the swivel bracket and the stern bracket.

Be sure to tilt the outboard motor down slowly.

Note

Slow down to trolling speed, and shift into Neutral before setting outboard motor to shallow water drive position.

ENGINE OPERATION

⚠ WARNING

- Run at lowest possible speed when using shallow water drive.
- Tilt lock is disabled when in shallow water drive position.
- When driving shallow water, be careful not to strike outboard motor against sea bottom, or propeller may be pushed out of water, resulting in loss of control.

1 Shallow water running position:

Put the reverse lock lever in the tilt up position, and tilt up the outboard motor to put the outboard motor in the shallow water running position.

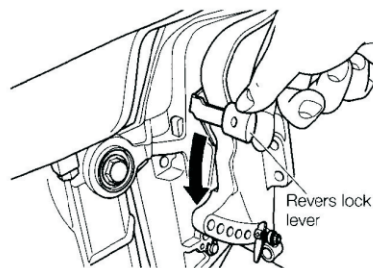

2 Return to normal running position:

Put the reverse lock lever in the tilt down position, slightly lift up the outboard motor, and then put it down.

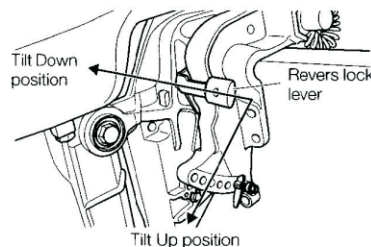

⚠ CAUTION

While in shallow water drive position, do not operate the outboard motor in reverse. Operate the outboard motor at slow speed and keep the cooling water intake submerged.

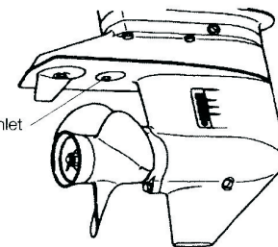

⚠ CAUTION

Do not overtilt outboard motor when driving shallow water, or air may be sucked through subwater inlet, potentially leading to engine overheating.

⚠ WARNING

Do not tilt up or down outboard motor when swimmer(s) or passenger is near to prevent them from being caught between outboard motor body and clamp bracket in case the outboard motor body falls.

⚠ WARNING

When tilting up outboard motor with fuel joint for over a few minutes, be sure to disconnect fuel hose or close fuel cock, or fuel may leak, potentially catching fire.

⚠ CAUTION

Do not tilt up outboard motor while engine operates, or no cooling water may be fed, leading to engine seizure due to overheating.

REMOVING AND CARRYING THE OUTBOARD MOTOR

1. Removing the outboard motor

- 1 Stop the engine.
- 2 Disconnect the fuel connector, the remote control cables and the battery cords from the outboard motor.
- 3 Remove the outboard motor from boat and completely drain the water from the gear case.

⚠ CAUTION

Engine may be hot immediately after operating and could cause burns if touched. Allow Engine to cool down before attempting to carry the outboard.

2. Carrying the outboard motor

Keep the outboard motor in a vertical position when carrying.

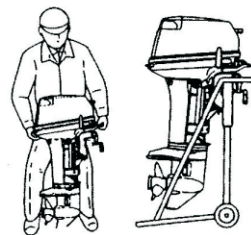

⚠ WARNING

Close air vent screw of fuel tank and fuel cock before carrying or storing outboard motor and fuel tank, or fuel may leak, potentially catching fire.

3. Storing the outboard motor

Outboard motor should be stored in a vertical position.

Note

If the outboard motor must be laid down be sure the tiller handle faces down as shown in the drawing below. Elevate power unit 2 inches to 4 inches if traveling to avoid oil spillage.

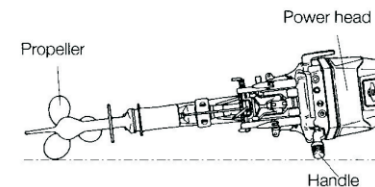

⚠ CAUTION

Do not carry or store outboard motor in any of positions described below. Otherwise, engine damage or property damage could result from leaking oil.

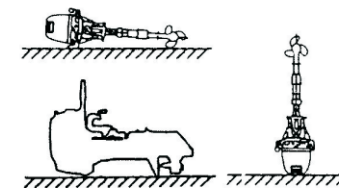

TRAILERING

⚠ WARNING

Do not go under outboard motor tilted up even if it is supported by support bar, or accidental fall of outboard motor could lead to severe personal injury.

⚠ WARNING

Close air vent screw of fuel tank and fuel cock before carrying or storing outboard motor and fuel tank, or fuel may leak, potentially catching fire.

⚠ WARNING

When taking outboard motor from package or removing outboard motor from the boat, never release the lock lever. If the lock lever is released, it will very easy for the clamp bracket to spring up to the tilting direction because it is not fixed.

*Care must be taken so as not to release lock lever by accident.

*For more safety, tie the clamp bracket to the outboard motor with a rope.

*Pay attention to the tilting direction so as not to be injured by the springing stern bracket.

⚠ CAUTION

The tilt support device supplied on your outboard motor is not intended for trailering. It is intended to support the outboard motor while the boat is docked, beached, etc.

⚠ CAUTION

When trailering the outboard motor should be in a vertical (normal running) position, fully down. Trailering in the tilted position

may cause damage to the outboard motor, boat, etc.

If trailering with outboard motor fully down is not available (the gear case skeg is too close to the road in a vertical position), fix the outboard motor securely using a device (like a transom saver bar) in the tilted position.

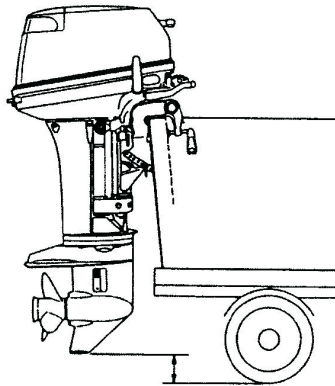

⚠ WARNING

Please disconnect fuel connector except when operating engine. Fuel leakage is a fire or explosion hazard, which can cause serious injury or death.

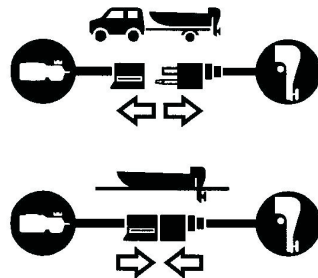

ADJUSTMENT

1. Trim tab adjustment

Adjustment of trim tab angle

After installing outboard motor on the boat, use trim tab to achieve balance between port and starboard steering loads. Loosen trim tab nut, adjust angle of trim tab as described below, and then tighten the nut to specified torque.

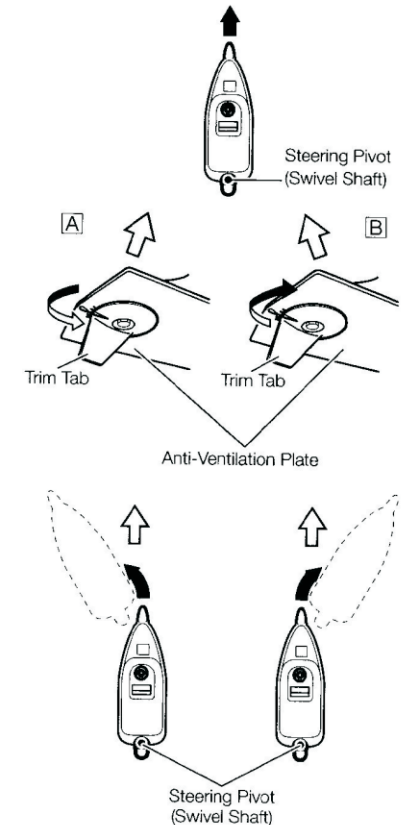
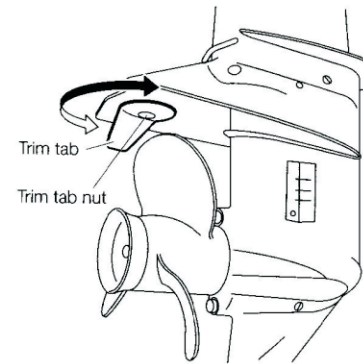

Example of Adjustment

To keep your outboard motor in the best operating condition, it is very important that you perform daily and periodic maintenance as suggested in the maintenance schedules that follow.

- Ⓐ If it is necessary to steer to port to make boat run straight or if boat steers itself to port when steering is held amidships, move trailing edge of trim tab to port side, or
- Ⓑ If it is necessary to steer to port to make boat run straight or if boat steers itself to starboard when steering is held amidships, move trailing edge of trim tab to starboard side.

Notes

- Change trim tab angle a little for each test run and repeat the process several times until the best position is found.
- The trim tab also acts as an anode to prevent electrolytic corrosion. Therefore do not paint or grease this part.
- After adjustment securely tighten the trim tab fixing bolt.
- Check for looseness of the bolt and the trim tab at regular intervals. Due to corrosion, the trim tab will wear down over time.

⚠ WARNING

- Inappropriate adjustment of trim tab could cause steering difficulty. After installing or readjusting trim tab, check if steering load is even.
- Tighten trim tab bolt to specified torque.

⚠ WARNING

- Be sure that outboard motor is secured to transom or service stand, or accidental drop or fall of outboard motor could lead to severe personal injury.
- Be sure to lock outboard motor if it is tilted up, or accidental fall of outboard motor could lead to severe personal injury.
- Do not go under outboard motor tilted up and locked, or accidental fall of outboard motor could lead to severe personal injury.

2. Steering load adjustment

Steering load can be adjusted by turning the steering adjust bolt on the Swivel Bracket.

Turn clockwise to increase load.
Turn counter-clockwise to decrease the load.

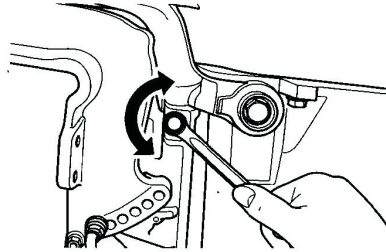

Note

The steering adjust bolt is used to adjust the sliding load of the steering, but not to fix the steering. If excess tightening given to the bolt may lead a cause of damage to the swivel bracket.

⚠ WARNING

Do not overtighten the throttle grip or remote control tensioner or it could result in difficulty of movement resulting in the loss of control causing an accident and could lead to severe injury.

3. Throttle grip turning load adjustment

Turn the friction adjustment screw on the steering handle to adjust the turning load of the throttle grip.

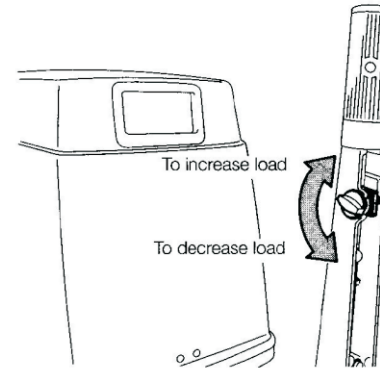

⚠ WARNING

Do not increase throttle friction excessively, or heavy movement of throttle grip or remote control lever movement could cause loss of throttle control potentially leading to accident.

INSPECTION AND MAINTENANCE

Care of your outboard motor

To keep your outboard motor in the best operating condition, it is very important that you perform daily and periodic maintenance as suggested in the maintenance schedules that follow.

CAUTION

- Your personal safety and that of your passengers depends on how well you maintain your outboard motor. Carefully observe all of the inspection and maintenance procedures described in this section.
- The maintenance intervals shown in the checklist apply to an outboard motor in normal use. If you use your outboard motor under severe conditions such as frequent full-throttle operation, frequent operation in brackish water, or for commercial use, maintenance should be performed at shorter intervals. If in doubt, consult your dealer for advice.
- We strongly recommend that you use only genuine replacement parts on your outboard motor. Damage to your outboard motor arising from the use of other than genuine parts is not covered under the warranty.

INSPECTION AND MAINTENANCE

1. Daily inspection

Perform the following checks and inspection before and after use.

WARNING

Do not use outboard motor on which any abnormality is found during pre-operation check, or it could go into trouble during cruising potentially leading to accident.

Item	Points to Check	Action
Fuel System	<ul style="list-style-type: none"> • Check the amount of fuel in the tank. • Check for dust or water in the fuel filter. • Check rubber pipes for oil leakage. 	Replenish Clean or replace Replace
Electrical Equipment	<ul style="list-style-type: none"> • Check that the stop switch functions normally and make sure the lock plate is there. • Check cords for loose connections and damage. • Check the spark plugs for dirt, wear and carbon build-up. 	Remedy or replace Correct or replace Clean or replace
Throttle System	<ul style="list-style-type: none"> • Check that the choke solenoid and valve for the carburetor function normally. • Check if the carburetor and magneto work normally when turning the throttle grip, and check links for looseness. 	Replace Correct
Recoil Starter	<ul style="list-style-type: none"> • Check ropes for wear and chafing. • Check the ratchet for engagement. 	Replace Correct or replace
Clutch and Propeller System	<ul style="list-style-type: none"> • Check that clutch engages correctly when operating the shift lever and remote control. • Visually check propeller for bent or damaged blades. • Check the propeller nut is tightened and the split pin is present. 	Adjust Replace.
Installation of Motor	<ul style="list-style-type: none"> • Check all the bolts attaching the motor to the boat. • Check the thrust rod installation. 	Tighten Tighten
Cooling Water	<ul style="list-style-type: none"> • Check that cooling water is discharged from the cooling water check port after the engine has started. 	Repair
Tools and Spares	<ul style="list-style-type: none"> • Check that there are tools and spare parts for replacing spark plugs, the propeller, etc. • Check that you have the spare rope. 	
Steering Devices	<ul style="list-style-type: none"> • Check the operation of the steering handle and remote control. 	Repair
Other Parts	<ul style="list-style-type: none"> • Check if the anode and trim tab are securely installed. • Check the anode and trim tab for corrosion and deformation. 	Repair if necessary Replace

INSPECTION AND MAINTENANCE

Washing with fresh water

If outboard motor is used in salt water, brackish water or water with a high acidic level, use fresh water to remove salt, chemicals or mud from exterior and cooling water passage after every cruising or before storing outboard motor for long time. Before flushing, remove the propeller and the forward thrust holder.

CAUTION

Keep cooling water passage free of clogs, or lack of cooling water flow could lead to engine overheating, potentially resulting in engine trouble.

WARNING

Do not start engine without removing propeller, or accidentally turning propeller could cause personal injury.

WARNING

Never start or operate the engine indoors or in any space which is not well ventilated. Exhaust gas contains carbon monoxide, a colorless and odorless gas which can be fatal if inhaled for any length of time.

Note

It is recommended to check chemical properties of water on which your outboard motor is regularly used.

■ Use flushing plug.

- 1 Remove propeller (refer to Propeller Replacement). Remove the water plug from the outboard motor, and screw in the flushing plug.

- 2 Attach a water hose to the flushing plug. Turn on the water and adjust the flow. (Be sure to seal the water inlet and sub water inlet, located in the gear case, with tape)
- 3 Insert a hose connected to a water tap into the flushing plug and let the water running.
- 4 Put the shift lever in the neutral position and start the engine.
- 5 Make sure of cooling water flowing out of water pump indicator hole and continue engine running for 3 to 5 minutes.
- 6 Stop the engine and water supply. Remove the flushing plug and tape, and then reinstall the water plug and the propeller.

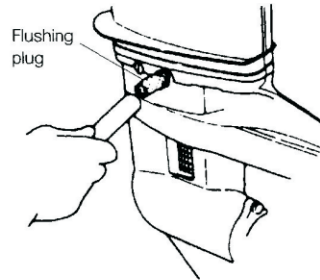

CAUTION

Keep engine at idle speed during flushing.

Replacing the propeller

A worn-out or bent propeller will lower the motor's performance, and cause engine trouble.

Before removing the propeller, remove the spark plug caps from the spark plugs to protect against personal injury.

INSPECTION AND MAINTENANCE

WARNING

Do not begin propeller removal and installation procedure with spark plug caps attached, shift in forward or reverse, main switch at other than "OFF", engine stop cord attached to the switch, and starter key attached, or engine could accidentally start leading to serious personal injury. Disconnect battery cable if possible.

- 1 Remove the split pin, propeller nut and washer.
- 2 Remove the propeller and thrust holder.
- 3 Apply genuine grease to the propeller shaft before installing a new propeller.
- 4 Install the thrust holder, propeller, washer and propeller nut onto the shaft.
- 5 Install a new split pin into the nut hole and bend it.

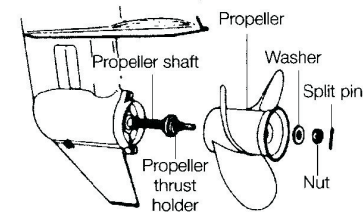

WARNING

Do not hold propeller with hand(s) when loosening or tightening propeller nut. Put a piece of wood block between propeller blade and anti-ventilation plate to hold propeller.

CAUTION

- Do not install propeller without thrust holder, or propeller boss could be damaged.
- Do not reuse split pin.

- After putting split pin, open the end to prevent it from coming off which could lead to coming off of propeller.

Replacing the spark plugs

WARNING

- Do not reuse spark plug with damaged insulation, or sparks can leak through crack, potentially leading to electric shock, explosion and/or fire.
- Do not touch spark plugs immediately after stopping engine as they will be hot and could cause severe burns if touched. Allow motor to cool down first.

Note

When inspecting the plug, always clean the gasket surface and use a new gasket. Wipe off any dirt from the threads and screw in the spark plug to the correct torque.

If the spark plug(s) is fouled, has carbon build up, or is worn, it should be replaced. When reusing spark plugs, remove dirt from the electrodes and adjust spark gap to specification.

- 1 Stop the engine.
- 2 Remove the top cowl.
- 3 Remove the spark plug caps.
- 4 Remove the spark plugs by turning it counter-clockwise, using a 21 mm (13/16 in) socket wrench and handle.
- 5 Attach spark plug and tighten to specified torque.

INSPECTION AND MAINTENANCE

Use spark plugs NGK BP7HS-10.

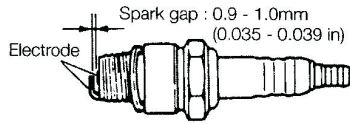

Notes

- **Spark plug torque :**
18.0 Nm (13.3 ft-lb) (1.8 kgf-m)

If a torque-wrench is not available when you are fitting a spark plug, a good estimate of the correct torque is 1/4 to 1/2 a turn past finger-tight. Have the spark plug adjusted to the correct torque as soon as possible with a torque-wrench.

Replacing the anode

A sacrificial anode protects the outboard motor from galvanic corrosion. Anode is located on the gear case and clamp bracket. When the anode is eroded more than 2/3, replace it.

Notes

- Never grease or paint the anode.
- At each inspection re-tighten the anode attaching bolt. As it is likely to be subjected to electrolytic corrosion.

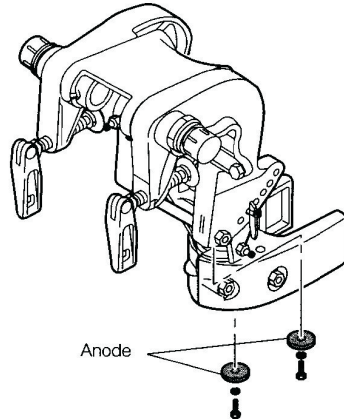
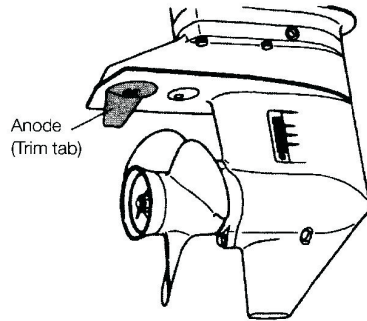

INSPECTION AND MAINTENANCE

2. Periodic inspection

It is important to inspect and maintain your outboard motor regularly. At each interval on the chart below, be sure to perform the indicated servicing. Maintenance intervals should be determined according to the number of hours or number of months, whichever comes first.

For periodic inspection and maintenance, consult your servicing dealer.

Item	Servicing Interval			Action	Remarks
	10 hours or 1 month	50 hours or 3 months	Every 100 hours or 6 months		
Fuel System	*Carburetor			●	Strip, clean and adjust. Adjust idling.
	Fuel filter	●	●	●	Check and clean or Replace if necessary.
	Piping/Hose	●	●	●	Check and Replace if necessary.
	Fuel tank	●		●	Clean.
Ignition	Spark plugs	●		●	Check gaps. Remove carbon deposits or Replace if necessary.
	*Ignition timing	●		●	Adjust timing.
Starting System	Starter rope	●	●	●	Check for wear or damage.
Lower Unit	Propeller	●	●	●	Check for bend blades, damage, wear.
	Gear oil	●	●	●	Change or replenish-oil and check for water leaks.
	*Water pump		●	●	Check for wear or damage. Replace impeller every 12 months.
Bolt and Nuts	●	●	●		Retighten.
Sliding and Rotating Parts. Grease Nipples		●	●		Apply and pump in grease.
Outer Equipment	●	●	●		Check for corrosion.
Anode		●	●		Check for corrosion and deformation. Replace if necessary.

*Have this handled by your dealer.

Note

Your outboard motor should receive careful, and complete, inspection at 300 hours. This is the best time for major maintenance procedures to be carried out.

Cleaning the fuel filters and the fuel tank

Fuel filters are provided inside the fuel tank and engine.

WARNING

Gasoline and its vapors are very flammable and can be explosive.

- Do not start this procedure while engine is operating or hot even after stopping it.
- Place fuel filter away from every source of ignition such as sparks or open flames.
- Wipe off gasoline well immediately if spilled.
- Install fuel filter with all related parts in place, or fuel leak could occur, leading to catching fire or explosion.
- Check fuel system regularly for leakage.
- Contact authorized dealer for fuel system services. Services by unqualified person could lead to engine damage.

■ Fuel filter (for engine)

Remove the cap, then clean the fuel filter in the engine.

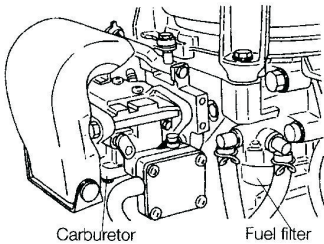

■ Fuel filter (for fuel tank)

Remove the fuel pickup elbow of the fuel tank by turning it counterclockwise and clean the fuel filter.

INSPECTION AND MAINTENANCE



■ Fuel tank

Water or dirt in the fuel tank will cause engine performance problems. Check and clean the tank at specified times or after the outboard motor has been stored for a long period of time (over three months).

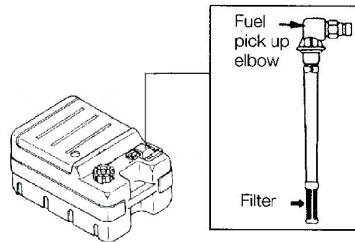

Replacing gear oil

WARNING

- Be sure that outboard motor is secured to transom or service stand, or accidental drop or fall of outboard motor could lead to severe personal injury.
- Be sure to lock outboard motor if it is tilted up, or accidental fall of outboard motor could lead to severe personal injury.
- Do not go under outboard motor tilted up and locked, or accidental fall of outboard motor could lead to severe personal injury.

INSPECTION AND MAINTENANCE

- 1 Remove the oil plugs (upper and lower), and completely drain the gear oil into a pan.

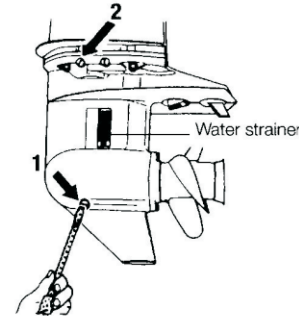

- 2 Insert the oil tube nozzle into the lower oil plug hole, and fill with gear oil by squeezing the oil tube until oil flows out of the upper plug hole.

CAUTION

Do not reuse oil plug gasket. Always use new gasket and tighten oil plug properly to prevent entry of water into lower unit.

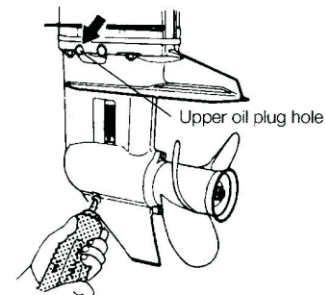

- 3 Install the upper oil plug, and then remove oil tube nozzle and install the lower oil plug.

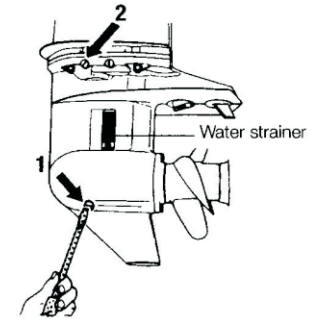

Note

If water in the oil, giving it a milky colored appearance. Contact your dealer.

Note

Use genuine gear oil or the recommended one (API GL-5: SAE #80 to #90).
Required volume : approx. 370 mL (0.10 U.S. gal.)

INSPECTION AND MAINTENANCE

3. Off-season storage

Before you put your outboard motor in storage, it is a good opportunity to have it serviced and prepared by your dealer.

CAUTION

Before servicing the motor for storage:

- Remove the battery cables.
- Remove the spark plug caps from the spark plugs.
- Do not run the motor out of the water.

■ Engine

- 1 Wash the engine exterior and flush the cooling water system thoroughly with fresh water. Drain the water completely. Wipe off any surface water with an oily rag.
- 2 Use a dry cloth to completely wipe off water and salt from the electrical components.
- 3 Drain all fuel from the fuel hoses, fuel pump, and carburetor, and clean these parts.
Keep in mind that if gasoline is kept in the carburetor for a long time, gum and varnish will develop, causing the float valve to stick, restricting the fuel flow.
- 4 Remove the spark plugs and feed genuine engine oil or storage fogging oil in through the spark plug holes.
The oil will be fed into the crank case from the air silencer attached to the carburetors. Turn the engine over several times while feeding the oil into it and make sure it is evenly distributed.
- 5 Change the gear oil in the gear case.
- 6 Apply grease to the propeller shaft.

- 7 Apply grease to all sliding parts, joints, nuts, and bolts.
- 8 Stand the outboard motor up vertically in a dry place.

WARNING

Be sure to use cloth to remove fuel remaining in the cowl and dispose of it in accordance with local fire prevention and environment protection regulations.

INSPECTION AND MAINTENANCE

4. Pre-season check

- 1 Check that the shift and throttle function properly.
(Be sure to turn the propeller shaft when checking the shift function or else the shift linkage may be damaged.)

CAUTION

The following steps must be taken when first using the engine after winter storage.

- 1 Fill up the fuel tank completely with 25 liters (6.6 U.S. gals.)
Mixing ratio : Gasoline 25 : 1 Engine oil
Use unleaded gasoline and genuine Outboard Motor Oil. If this oil is not available, use NMMA TC-W3 certified outboard motor oil.
- 2 Warm up the engine for 3 minutes in the "NEUTRAL" position.
- 3 Run the engine for 5 minutes at the slowest speed.
- 4 Run the engine for 10 minutes at half speed.

In Steps 2 and 3 above, the oil used for storage inside the engine will be flushed out to assure optimum performance.

- 2 Clean the fuel filter.

5. Motor submerged in water

After taking your outboard motor out of the water, immediately take it to your dealer. The following are the emergency measures to be taken for a submerged outboard motor, if you can not take it your dealer right away.

- 1 Wash the outboard motor with fresh water to remove salt or dirt.
- 2 Remove the spark plugs, and completely drain the water from the engine by pulling the recoil starter several times.
- 3 Inject a sufficient amount of genuine engine oil through the spark plug hole and into the crank case from the carburetor side. Pull the recoil starter several times to circulate the oil throughout the outboard motor.

CAUTION

Do not attempt to start submerged outboard motor immediately after it is recovered, or engine could be severely damaged.

6. Cold weather precautions

If you moor your boat in cold weather at temperatures below 0°C (32°F), there is the danger of water freezing in the cooling water pump, which may damage the pump, impeller, etc. To avoid this problem, submerge the lower half of the outboard motor into the water, or tilt the motor up above water level and pull the recoil starter several times to drain the water completely.

7. Checking after striking underwater object

Striking the sea bottom or an underwater object may severely damage the outboard motor. Immediately bring the outboard motor to the dealer and ask for the following checks.

- 1 Looseness or damage of power unit installation bolts, gear case and extension case bolts, propeller shaft housing bolts, propeller or propeller shaft upper and lower mount rubber bolts, and/or mount bracket bolts.

Ask an authorized dealer to tighten any loose bolts and nuts, and to replace damaged parts.

- 2 Damage to mount rubber, the tilt stopper, thrust rod, gears and clutch, and/or propeller.

Ask an authorized dealer to replace damaged or defective parts.

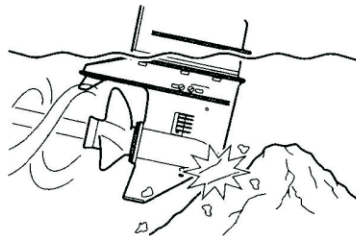

TROUBLESHOOTING

If you encounter problem with the engine, check the list below and locate the problem you are experiencing. Then follow the suggested remedies.

Do not hesitate to contact your dealer, as professional advice and assistance is the best way to keep the engine in optimum condition.

Difficult to start engine	Engine starts, but stops soon	Poor idling	Unstable engine running speed or engine stops	Abnormally high engine speed	Abnormally low engine speeds	Cannot obtain high engine speeds	Overheating of engine	
•	•		•					Empty fuel tank
•	•	•	•		•	•	•	Incorrect connection of fuel system
•	•	•	•		•	•	•	Air enters fuel line
•	•	•	•		•	•	•	Deformed or damaged fuel pipe
•	•	•	•		•	•	•	Closed air vent on fuel tank cap
•	•	•	•		•	•	•	Clogged fuel filter, fuel pump or carburetor
		•	•		•	•	•	Use of improper engine oil
•	•	•	•			•	•	Use of improper gasoline
•	•							Excessive supply of gasoline
•	•	•	•		•	•	•	Poor carburetor adjustment
•	•	•	•			•	•	Recirculation pipe broken
•	•	•	•		•	•	•	Use of non-specified spark plugs
•	•	•	•		•	•		Dirt or carbon deposits on spark plugs

TROUBLESHOOTING

Difficult to start engine	Engine starts, but stops soon	Poor idling	Unstable engine running speed or engine stops	Abnormally high engine speed	Abnormally low engine speeds	Cannot obtain high engine speeds	Overheating of engine	
●	●	●	●		●	●		No sparks or weak sparks
			●		●	●	●	Insufficient cooling water flow
		●	●			●	●	Faulty thermostat
				●		●	●	Propeller cavitation
				●	●	●	●	Incorrect propeller selection
		●		●	●	●	●	Damaged or bent propeller
				●	●	●	●	Unbalanced load in boat
				●		●	●	Transom too high
					●	●	●	Transom too low
●	●	●			●	●	●	Incorrect adjustment of throttle link
●	●	●			●	●	●	Incorrect adjustment of ignition timing
●								Insufficient battery capacity, loose terminals, corrosion
●								Safety switch lock plate not fitted